

HM1K, HM2K

Датчики протока поршневого типа

GHM MESSTECHNIK



Технические характеристики

| | | | | |
|-----------------------------|----------------------------|---------------------------------|--------------------------------|---------------------------|
| Архангельск (8182)63-90-72 | Иваново (4932)77-34-06 | Липецк (4742)52-20-81 | Пенза (8412)22-31-16 | Ставрополь (8652)20-65-13 |
| Астана (7172)727-132 | Ижевск (3412)26-03-58 | Магнитогорск (3519)55-03-13 | Пермь (342)205-81-47 | Сурут (3462)77-98-35 |
| Астрахань (8512)99-46-04 | Иркутск (395)279-98-46 | Москва (495)268-04-70 | Ростов-на-Дону (863)308-18-15 | Тверь (4822)63-31-35 |
| Барнаул (3852)73-04-60 | Казань (843)206-01-48 | Мурманск (8152)59-64-93 | Рязань (4912)46-61-64 | Томск (3822)98-41-53 |
| Белгород (4722)40-23-64 | Калининград (4012)72-03-81 | Набережные Челны (8552)20-53-41 | Самара (846)206-03-16 | Тула (4872)74-02-29 |
| Брянск (4832)59-03-52 | Калуга (4842)92-23-67 | Нижний Новгород (831)429-08-12 | Санкт-Петербург (812)309-46-40 | Тюмень (3452)66-21-18 |
| Владивосток (423)249-28-31 | Кемерово (3842)65-04-62 | Новокузнецк (3843)20-46-81 | Саратов (845)249-38-78 | Ульяновск (8422)24-23-59 |
| Волгоград (844)278-03-48 | Киров (8332)68-02-04 | Новосибирск (383)227-86-73 | Севастополь (8692)22-31-93 | Уфа (347)229-48-12 |
| Вологда (8172)26-41-59 | Краснодар (861)203-40-90 | Омск (3812)21-46-40 | Симферополь (3652)67-13-56 | Хабаровск (4212)92-98-04 |
| Воронеж (473)204-51-73 | Красноярск (391)204-63-61 | Орел (4862)44-53-42 | Смоленск (4812)29-41-54 | Челябинск (351)202-03-61 |
| Екатеринбург (343)384-55-89 | Курск (4712)77-13-04 | Оренбург (3532)37-68-04 | Сочи (862)225-72-31 | Череповец (8202)49-02-64 |

Киргизия (996)312-96-26-47 Казахстан (772)734-952-31 Таджикистан (992)427-82-92-69

Flow Switch HM1K



- High switching power
- Compact design

Characteristics

Mechanical flow switch, for fluid or gaseous media, with spring-supported piston and magnetic triggering of a microswitch. Robust construction in brass or stainless steel.

Technical data

| | | |
|------------------------------|--|-----------------------------------|
| Switch | microswitch | |
| Nominal width | DN 8..25 | |
| Process connection | female thread G 1/4..G 1 (further process connections available on request) | |
| Switching range | 0.1..74 l/min | for details see table "Ranges" |
| Pressure loss | 0.4..1.6 bar at Q _{max.} | |
| Q_{max.} | to 100 l/min | |
| Tolerance | ±5 % of full scale value | |
| Pressure resistance | PN 200 bar | |
| Media temperature | -20..+70 °C | |
| Ambient temperature | -20..+70 °C | |
| Media | water, oil (gases and aggressive media available on request) | |
| Wiring | changeover No. 0.371 | |
| | optionally changeover No. 0.282 | |
| Switching voltage | max. 250 V AC | |
| Switching current | max. 5 A (round plug connector max. 4A) | |
| Protection class | 2 - safety insulation | |
| Ingress protection | IP 65 | |
| Electrical connection | plug DIN 43650-A / ISO 4400 optionally for round plug connector M12x1, 4-pole | |

| | | |
|-------------------------------------|---|---|
| Materials medium-contact | Brass construction: CW614N nickelled, CW614N, 1.4310, hard ferrite, NBR | Stainless steel construction: 1.4571, 1.4404, 1.4310, hard ferrite PTFE-coated, FKM |
| Non-medium-contact materials | PA, CW614N, NBR | |
| Weight | see table "Dimensions and weights" | |
| Installation location | horizontal inwards flow; switching head on top. | |

Ranges

For switching ranges, the details in the table correspond to horizontal inwards flow and decreasing flow rate; for display ranges they correspond to horizontal inwards flow and increasing flow rate.

Standard type HM1K

| Switching range l/min H ₂ O | Optionally Display range l/min H ₂ O | Q _{max.} recommended | Pressure loss bar at Q _{max.} H ₂ O |
|---|--|----------------------------------|--|
| 0.1 - 0.8 | 0.1 - 1.2 | 6 | 0,4 |
| 0.5 - 4.0 | 0.5 - 6.0 | 10 | 0,5 |
| 1.0 - 8.0 | 1.0 - 12.0 | 20 | 0,6 |
| 2.0 - 16.0 | 2.0 - 23.0 | 30 | 0,4 |
| 3.0 - 26.0 | 3.0 - 34.0 | 40 | |
| 4.0 - 36.0 | 4.0 - 45.0 | 60 | 0,8 |
| 6.0 - 55.0 | 6.0 - 65.0 | 80 | 1,4 |
| 20.0 - 74.0 | 20.0 - 85.0 | 100 | 1,6 |

Special ranges are available.

Product Information

Sensors and Instrumentation

Dimensions and weights

| | G | Types | SW | X | Weight kg |
|-----------------|-------|-----------|----|----|--------------|
| Brass | G 1/4 | ...-008GM | 40 | 15 | 1.4 |
| | G 3/8 | ...-010GM | | | |
| | G 1/2 | ...-015GM | | 18 | 1.3 |
| | G 3/4 | ...-020GM | | | |
| | G 1 | ...-025GM | | | |
| Stainless steel | G 1/4 | ...-008GK | 41 | 15 | 1.4 |
| | G 3/8 | ...-010GK | | | |
| | G 1/2 | ...-015GK | | 18 | 1.3 |
| | G 3/4 | ...-020GK | | | |
| | G 1 | ...-025GK | | | |

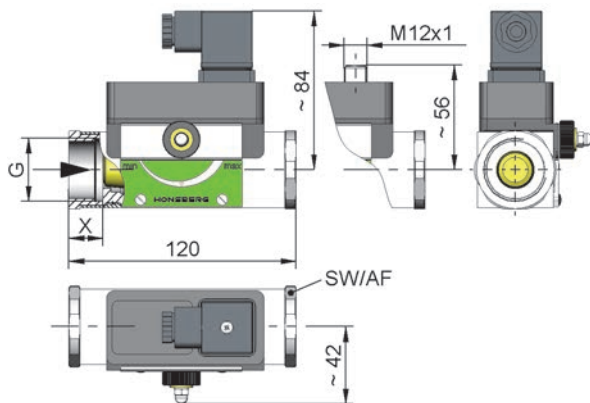

Handling and operation

Note

- Include straight calming section of 5 x DN in inlet and outlet
- If the media are dirty, install a filter (use magnetic filter for ferritic components).
- It must be ensured that the values given for voltage, current, and power are not exceeded.
- When switch on, a load must be connected in series.
- The electrical details apply to ohmic loads. Capacitive and inductive loads must be operated using a protective circuit.

Adjustment

If it is necessary to set the switching value, the switching head can be adjusted by adjustment of a pinion. When the switching value is reached, the switching unit is fixed in place by a fastening bolt (SW 8).



Ordering code

HM 1. 2. 3. 4. 5.
 G

| | |
|---|-------------------------------------|
| 1. Display options | |
| - | no mechanical display |
| O1- | with measurement display at side O1 |
| O- | with measurement display at side O |
| 2. Nominal width | |
| 008 | DN 8 - G 1/4 |
| 010 | DN 10 - G 3/8 |
| 015 | DN 15 - G 1/2 |
| 020 | DN 20 - G 3/4 |
| 025 | DN 25 - G 1 |
| 3. Process connection | |
| G | female thread |
| 4. Connection material | |
| M | brass |
| K | stainless steel |
| 5. HM1K - switching range H₂O for horizontal inwards flow | |
| 001 | 0.1 - 0.8 l/min |
| 004 | 0.5 - 4.0 l/min |
| 008 | 1.0 - 8.0 l/min |
| 016 | 2.0 - 16.0 l/min |
| 026 | 3.0 - 26.0 l/min |
| 036 | 4.0 - 36.0 l/min |
| 055 | 6.0 - 55.0 l/min |
| 074 | 20.0 - 74.0 l/min |

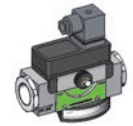

HM.KO1-

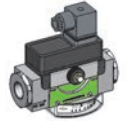

HM.KO-

Options

- Signal lamp red or red / green in the plug DIN 43650-A
- Gold contact
- Reinforced piston (only if made of brass)
- Connection for round plug connector M12x1
- Switching head with metal cap
- Adjustment scale with markings in l/min
- Switching values for oil or gas
- Special values
- Temperature display 0..120 °C

Ordering information

- Specify direction of flow, medium, and switching range.
- For viscous media specify viscosity, temperature, and medium (e.g. ISO VG 68) (enquire about switching range).
- For gases, state pressure (relative or absolute), temperature and medium (e.g. air) (request switching range).

Flow Switch HM2K



- High switching power
- Compact design

Characteristics

Mechanical flow switch, for fluid or gaseous media, with spring-supported piston and magnetic triggering of a microswitch. Robust construction in brass or stainless steel.

Technical data

| | | |
|------------------------------|--|--------------------------------|
| Switch | microswitch | |
| Nominal width | DN 8..25 | |
| Process connection | female thread G 1/4..G 1 (further process connections available on request) | |
| Switching range | 0.5..55 l/min | for details see table "Ranges" |
| Pressure loss | 1.1..3.5 bar at Q _{max.} | |
| Q_{max.} | to 80 l/min | |
| Tolerance | ±5 % of full scale value | |
| Pressure resistance | PN 200 bar | |
| Media temperature | -20..+70 °C | |
| Ambient temperature | -20..+70 °C | |
| Media | oil | |
| Wiring | changeover No. 0.371 | |
| | optionally changeover No. 0.282 | |
| Switching voltage | max. 250 V AC | |
| Switching current | max. 5 A (round plug connector max. 4A) | |
| Protection class | 2 - safety insulation | |
| Ingress protection | IP 65 | |
| Electrical connection | plug DIN 43650-A / ISO 4400 optionally for round plug connector M12x1, 4-pole | |

| | | |
|-------------------------------------|--|--|
| Materials medium-contact | <i>Brass construction:</i> CW614N nickelled, CW614N, 1.4310, hard ferrite, NBR | <i>Stainless steel construction:</i> 1.4571, 1.4404, 1.4310, hard ferrite PTFE-coated, FKM |
| Non-medium-contact materials | PA, CW614N, NBR | |
| Weight | see table "Dimensions and weights" | |
| Installation location | horizontal inwards flow; switching head on top. | |

Ranges

For switching ranges, the details in the table correspond to horizontal inwards flow and decreasing flow rate; for display ranges they correspond to horizontal inwards flow and increasing flow rate.

Viscosity compensated HM2K

| Switching range | Optionally Display range | Q _{max.} recommended | Pressure loss bar at Q _{max.} oil mm ² /s | | | | | Viscosity stability |
|---|--------------------------|-------------------------------|---|-----|-----|-----|-----|---------------------|
| | | | 30 | 60 | 100 | 205 | 330 | |
| l/min oil 30..330 mm ² /s | | | | | | | | ±8 %, min. |
| 0.5 - 0.6 | 0.5 - 10 | 12 | 1.1 | 1.4 | 1.6 | 2.8 | 3.5 | ±0.3 l/min |
| 1.5 - 12.0 | 1.5 - 20 | 22 | 2.2 | 2.3 | 2.4 | | | ±0.5 l/min |
| 2.5 - 22.0 | 2.5 - 30 | 35 | 1.9 | 2.0 | 2.1 | 2.3 | 2.9 | ±0.8 l/min |
| 6.0 - 36.0 | 6.0 - 45 | 60 | | | | | 2.6 | ±2.7 l/min |
| 12.0 - 55.0 | 12.0 - 65 | 80 | 2.1 | 2.3 | 2.4 | 2.6 | 2.8 | ±3 l/min |

Special ranges are available.

Dimensions and weights

| | G | Types | SW | X | Weight kg |
|------------------------|-------|-----------|----|----|-----------|
| Brass | G 1/4 | ...-008GM | 40 | 15 | 1.4 |
| | G 3/8 | ...-010GM | | | |
| | G 1/2 | ...-015GM | | 18 | 1.3 |
| | G 3/4 | ...-020GM | | | |
| | G 1 | ...-025GM | | | |
| Stainless steel | G 1/4 | ...-008GK | 41 | 15 | 1.4 |
| | G 3/8 | ...-010GK | | | |
| | G 1/2 | ...-015GK | | 18 | 1.3 |
| | G 3/4 | ...-020GK | | | |
| | G 1 | ...-025GK | | | |

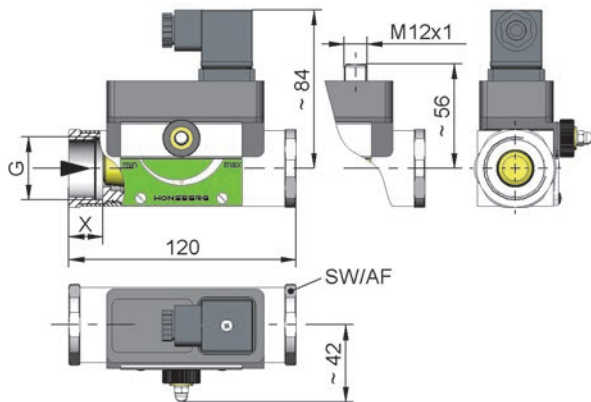

Handling and operation

Note

- Include straight calming section of 5 x DN in inlet and outlet
- If the media are dirty, install a filter (use magnetic filter for ferritic components).
- It must be ensured that the values given for voltage, current, and power are not exceeded.
- When switch on, a load must be connected in series.
- The electrical details apply to ohmic loads. Capacitive and inductive loads must be operated using a protective circuit.

Adjustment

If it is necessary to set the switching value, the switching head can be adjusted by adjustment of a pinion. When the switching value is reached, the switching unit is fixed in place by a fastening bolt (SW 8).



Ordering code

HM 1. 2. 3. 4. 5.

| | |
|---|-------------------------------------|
| 1. Display options | |
| - | no mechanical display |
| O1- | with measurement display at side O1 |
| O- | with measurement display at side O |
| 2. Nominal width | |
| 008 | DN 8 - G 1/4 |
| 010 | DN 10 - G 3/8 |
| 015 | DN 15 - G 1/2 |
| 020 | DN 20 - G 3/4 |
| 025 | DN 25 - G 1 |
| 3. Process connection | |
| G | female thread |
| 4. Connection material | |
| M | brass |
| K | stainless steel |
| 5. HM2K - switching range oil 30..330 mm²/s for horizontal inwards flow | |
| 006 | 0.5 - 6.0 l/min |
| 012 | 1.5 - 12.0 l/min |
| 022 | 2.5 - 22.0 l/min |
| 036 | 6.0 - 36.0 l/min |
| 055 | 12.0 - 55.0 l/min |

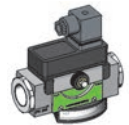

HM.KO1-

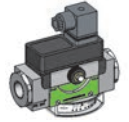

HM.KO-

Options

- Signal lamp red or red / green in the plug DIN 43650-A
- Gold contact
- Connection for round plug connector M12x1
- Switching head with metal cap
- Adjustment scale with markings in l/min
- Special values
- Temperature display 0..120 °C

Ordering information

- Specify direction of flow, medium, and switching range.
- For viscous media specify viscosity, temperature, and medium (e.g. ISO VG 68) (enquire about switching range).

Архангельск (8182)63-90-72
 Астана (7172)727-132
 Астрахань (8512)99-46-04
 Барнаул (3852)73-04-60
 Белгород (4722)40-23-64
 Брянск (4832)59-03-52
 Владивосток (423)249-28-31
 Волгоград (844)278-03-48
 Вологда (8172)26-41-59
 Воронеж (473)204-51-73
 Екатеринбург (343)384-55-89

Иваново (4932)77-34-06
 Ижевск (3412)26-03-58
 Иркутск (395)279-98-46
 Казань (843)206-01-48
 Калининград (4012)72-03-81
 Калуга (4842)92-23-67
 Кемерово (3842)65-04-62
 Киров (8332)68-02-04
 Краснодар (861)203-40-90
 Красноярск (391)204-63-61
 Курск (4712)77-13-04

Липецк (4742)52-20-81
 Магнитогорск (3519)55-03-13
 Москва (495)268-04-70
 Мурманск (8152)59-64-93
 Набережные Челны (8552)20-53-41
 Нижний Новгород (831)429-08-12
 Новокузнецк (3843)20-46-81
 Новосибирск (383)227-86-73
 Омск (3812)21-46-40
 Орел (4862)44-53-42
 Оренбург (3532)37-68-04

Пенза (8412)22-31-16
 Пермь (342)205-81-47
 Ростов-на-Дону (863)308-18-15
 Рязань (4912)46-61-64
 Самара (846)206-03-16
 Санкт-Петербург (812)309-46-40
 Саратов (845)249-38-78
 Севастополь (8692)22-31-93
 Симферополь (3652)67-13-56
 Смоленск (4812)29-41-54
 Сочи (862)225-72-31

Ставрополь (8652)20-65-13
 Сургут (3462)77-98-35
 Тверь (4822)63-31-35
 Томск (3822)98-41-53
 Тула (4872)74-02-29
 Тюмень (3452)66-21-18
 Ульяновск (8422)24-23-59
 Уфа (347)229-48-12
 Хабаровск (4212)92-98-04
 Челябинск (351)202-03-61
 Череповец (8202)49-02-64
 Ярославль (4852)69-52-93

Киргизия (996)312-96-26-47 Казахстан (772)734-952-31 Таджикистан (992)427-82-92-69